

# TPSMB Series

ROHS

## 13 To 200V 600W

### Surface Mount Transient Voltage Suppressors

#### Description

TVS diodes can be used in a wide range of applications which like consumer electronic products, automotive industries, munitions, telecommunications, aerospace industries, and intelligent control systems.

Working Voltage: 13 to 200V

Peak Pulse Power: 600W

#### Features

- ◆ Glass passivated chip
- ◆ 600W peak pulse power capability with a 10/1000us waveform, repetitive rate (duty cycle):0.01%
- ◆ High reliability application and automotive grade AEC Q101 qualified
- ◆ Low leakage
- ◆ Uni and Bidirectional unit
- ◆ Excellent clamping capability
- ◆ Very fast response time
- ◆ Plastic package has Underwriters Laboratory Flammability 94V-0
- ◆ Halogen free and RoHS compliant
- ◆ IEC-61000-4-2 ESD 30kV(Air), 30kV (Contact)
- ◆ ESD protection of data lines in accordance with IEC 61000-4-2
- ◆ EFT protection of data lines in accordance with IEC 61000-4-4

#### Applications

TVS devices are ideal for the protection of I/O interfaces, Vcc bus and other vulnerable circuits used in Telecom, Computer, Industrial and Consumer electronic applications.

#### Maximum Ratings and Thermal Characteristics(TA=25°C unless otherwise noted)

Parameter	Symbol	Value	Unit
Peak power dissipation with a 10/1000us waveform <sup>(1)</sup>	PPPM	600	W
Power Dissipation on Infinite Heat Sink at TL=75°C	PD	5.0	W
Peak pulse current with a 10/1000us waveform <sup>(1)</sup>	IPP	See Next Table	A
Junction and storage temperature range	TJ , TSTG	- 55 to +150	°C
Operating storage temperature range	TOP	- 55 to +150	°C
Maximum Instantaneous Forward Voltage at 25A for Unidirectional	VF	3.5	V
Peak forward surge current, 8.3 ms single half sine-wave unidirectional only <sup>(2)</sup>	IFSM	100	A

Note: (1) Non-repetitive current pulse per Fig.5 and derated above TA= 25°Cper Fig.1

(2) Measured on 8.3 ms single half sine-wave or equivalent square wave, duty cycle = 4 pulses per minute maximum



www.unsemi.com.tw

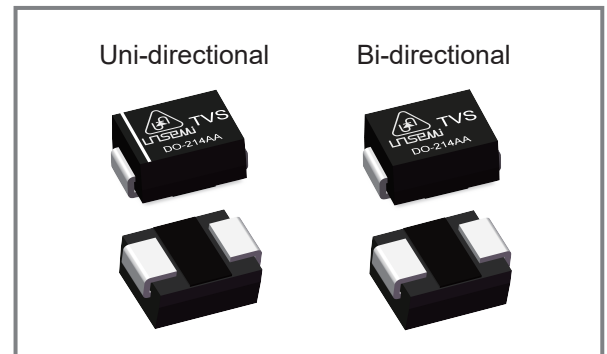

#### Mechanical Data

- ◆ Case: Molded plastic
- ◆ Epoxy: UL 94V-0 rate flame retardant
- ◆ Lead: Solderable per MIL-STD-750, method 2026
- ◆ Polarity: Color band denotes cathode end except Bipolar
- ◆ Mounting position: Any

**Electrical Characteristics (@25°C Unless Otherwise Specified)**

Part Number		Marking		Reverse Stand-Off Voltage $V_{RWM}$ (V)	Breakdown Voltage $V_{BR}$ (V) @ $I_T$		Test Current $I_T$ (mA)	Maximum Clamping Voltage $V_C$ @ $I_{PP}$ (V)	Maximum Peak Pulse Current $I_{PP}$ (A)	Maximum Reverse Leakage $I_R$ @ $V_{RWM}$ ( $\mu$ A)
Uni	Bi	Uni	Bi		MIN	MAX				
TPSMB13A	TPSMB13CA	13AA	13CA	11.1	12.35	13.65	1	18.20	32.97	5
TPSMB15A	TPSMB15CA	15AA	15CA	12.8	14.25	15.75	1	21.20	28.30	1
TPSMB16A	TPSMB16CA	16AA	16CA	13.6	15.20	16.80	1	22.50	26.67	1
TPSMB18A	TPSMB18CA	18AA	18CA	15.3	17.10	18.90	1	25.20	23.81	1
TPSMB20A	TPSMB20CA	20AA	20CA	17.1	19.00	21.00	1	27.70	21.66	1
TPSMB22A	TPSMB22CA	22AA	22CA	18.8	20.90	23.10	1	30.60	19.61	1
TPSMB24A	TPSMB24CA	24AA	24CA	20.5	22.80	25.20	1	33.20	18.07	1
TPSMB27A	TPSMB27CA	27AA	27CA	23.1	25.65	28.35	1	37.50	16.00	1
TPSMB30A	TPSMB30CA	30AA	30CA	25.6	28.50	31.50	1	41.40	14.49	1
TPSMB33A	TPSMB33CA	33AA	33CA	28.2	31.35	34.65	1	45.70	13.13	1
TPSMB36A	TPSMB36CA	36AA	36CA	30.8	34.20	37.80	1	49.90	12.02	1
TPSMB39A	TPSMB39CA	39AA	39CA	33.3	37.05	40.95	1	53.90	11.13	1
TPSMB43A	TPSMB43CA	43AA	43CA	36.8	40.85	45.15	1	59.30	10.12	1
TPSMB47A	TPSMB47CA	47AA	47CA	40.2	44.65	49.35	1	64.80	9.26	1
TPSMB51A	TPSMB51CA	51AA	51CA	43.6	48.45	53.55	1	70.10	8.56	1
TPSMB56A	TPSMB56CA	56AA	56CA	47.8	53.20	58.80	1	77.00	7.79	1
TPSMB62A	TPSMB62CA	62AA	62CA	53.0	58.90	65.10	1	85.00	7.06	1
TPSMB68A	TPSMB68CA	68AA	68CA	58.1	64.60	71.40	1	92.00	6.52	1
TPSMB75A	TPSMB75CA	75AA	75CA	64.1	71.25	78.75	1	103.0	5.83	1
TPSMB82A	TPSMB82CA	82AA	82CA	70.1	77.90	86.10	1	113.0	5.31	1
TPSMB91A	TPSMB91CA	91AA	91CA	77.8	86.45	95.55	1	125.0	4.80	1
TPSMB100A	TPSMB100CA	100AA	100CA	85.5	95.00	105.0	1	137.0	4.38	1
TPSMB110A	TPSMB110CA	110AA	110CA	94.0	104.5	115.5	1	152.0	3.95	1
TPSMB120A	TPSMB120CA	120AA	120CA	102.0	114.0	126.0	1	165.0	3.64	1
TPSMB130A	TPSMB130CA	130AA	130CA	111.0	123.5	136.5	1	179.0	3.35	1
TPSMB150A	TPSMB150CA	150AA	150CA	128.0	142.5	157.5	1	207.0	2.90	1
TPSMB160A	TPSMB160CA	160AA	160CA	136.0	152.0	168.0	1	219.0	2.74	1
TPSMB170A	TPSMB170CA	170AA	170CA	145.0	161.5	178.5	1	234.0	2.56	1
TPSMB180A	TPSMB180CA	180AA	180CA	154.0	171.0	189.0	1	246.0	2.44	1
TPSMB200A	TPSMB200CA	200AA	200CA	171.0	190.0	210.0	1	274.0	2.19	1

**Note:**

(1) Add suffix 'C' or 'CA' after part number to specify Bi-directional devices

Ratings and Characteristic Curves (TA=25°C unless otherwise noted)

Figure 1 - Pulse Waveform

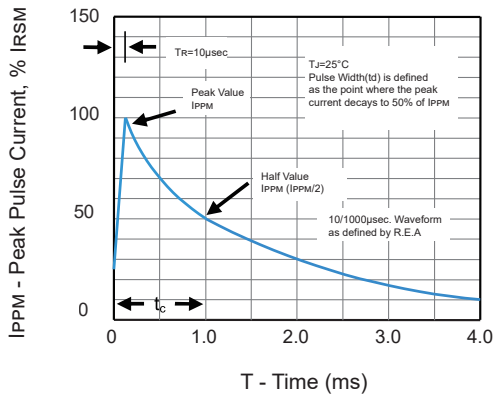

Figure 2 - Pulse Derating Curve

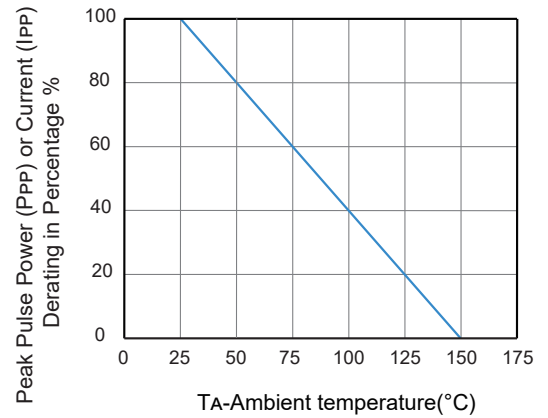

Figure 3 - Peak Pulse Power Rating Curve

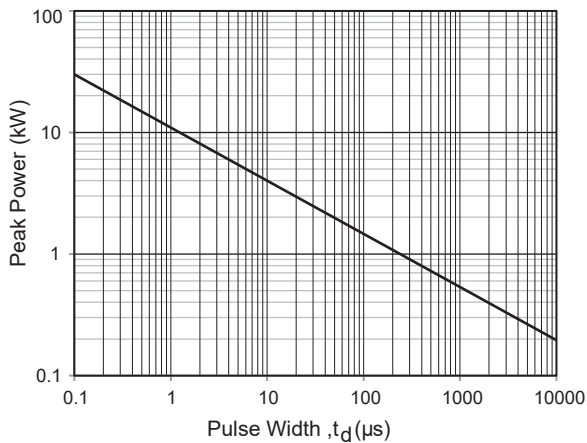
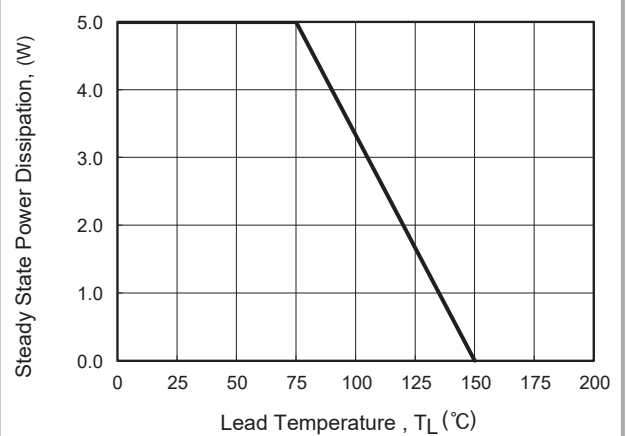
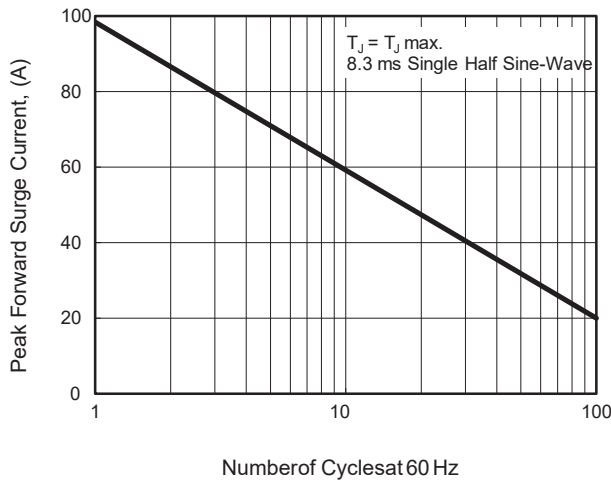

Figure 4 - Steady State Power Derating Curve



**Ratings and Characteristic Curves (TA=25°C unless otherwise noted)**

**Figure 5 - Maximum Non-Repetitive Surge Current**



**Figure 6 - Typical Junction Capacitance**

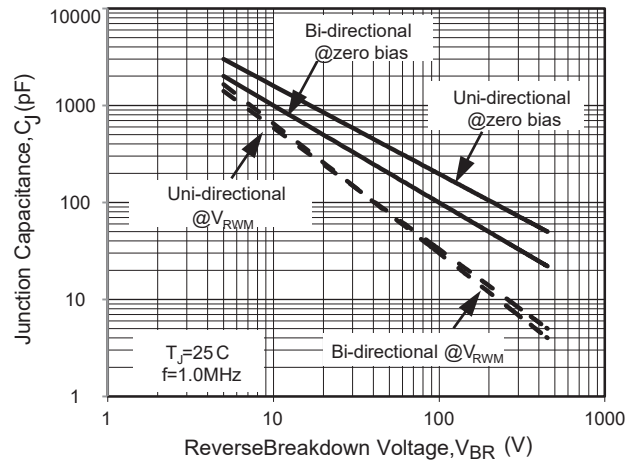

**Part Numbering**

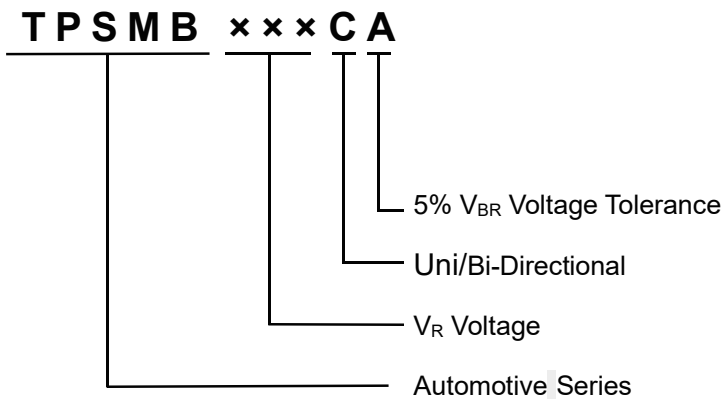

### Soldering Parameters

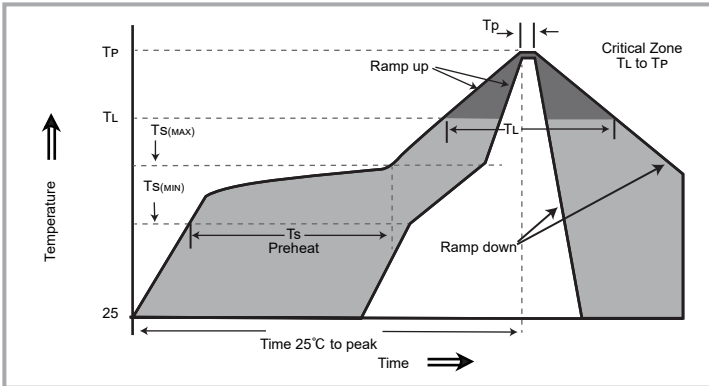

Reflow Condition		Lead-free assembly
Pre Heat	-Temperature Min (Ts(min))	150°C
	-Temperature Max (Ts(max))	200°C
	- Time (min to max) (Ts)	60 -180 Seconds
Average ramp up rate ( Liquidus Temp TL) to peak		3°C/second max
Ts(max) to TL - Ramp-up Rate		5°C/second max
Reflow	- Temperature (TL) (Liquidus)	217°C
	- Time (min to max) (Ts)	60 -150 Seconds
Peak Temperature (TP)		260 +0/-5°C
Time within 5°C of actual peak Temperature (TP)		20 - 40 Seconds
Ramp-down Rate		6°C/second max
Time 25°C to peak Temperature (TP)		8 minutes Max
Do not exceed		280°C

### Dimensions

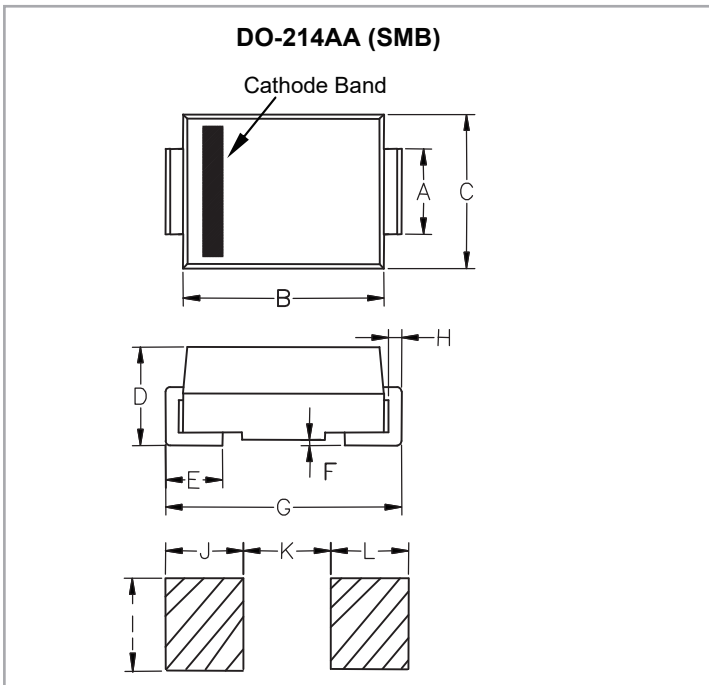

Dimensions	Inches		Millimeters	
	Min	Max	Min	Max
A	0.077	0.087	1.960	2.200
B	0.171	0.191	4.350	4.850
C	0.130	0.155	3.300	3.940
D	0.084	0.096	2.130	2.440
E	0.030	0.060	0.750	1.520
F	-	0.008	-	0.203
G	0.201	0.216	5.100	5.500
H	0.006	0.012	0.152	0.305
I	0.089	-	2.260	-
J	0.085	-	2.160	-
K	-	0.107	-	2.740
L	0.085	-	2.160	-

## Disclaimer

UNSEMI RESERVES THE RIGHT TO MAKE CHANGE ON OUR PRODUCTS , PRODUCTS SPECIFICATION AND DATA WITHOUT NOTICE TO IMPROVE RELIABILITY, FUNCTION OR DESIGN OR OTHERWISE.

UN SEMICONDUCTOR LIMITED its affiliates, agents, and employees, and all persons acting on its or their behalf (collectively, "UNSEMI") does not give any representations or warranties for any errors, inaccuracies or incompleteness contained in any datasheet or in any other disclosure relating to any product.

In no event shall UNSEMI be liable for any indirect, incidental, punitive, special or consequential damages (including any and all implied warranties, warranties of fitness for particular purpose, non-infringement and merchantability.) whether or not such damages are based on tort (including negligence), warranty, breach of contract or any other legal theory.

Statements regarding the suitability of products for certain types of applications are based on UNSEMI knowledge of typical requirements that are often placed on UNSEMI products in generic applications. Such statements are not binding, statements about the suitability of products for a particular application. It is the customer's responsibility to validate that a particular product with the properties described in the product specification is suitable for use in a particular application. Parameters provided in datasheets or specifications may vary in different applications and performance may vary over time. All operating parameters, including typical parameters, must be validated for each customer application by the customer's technical experts. Product specifications do not expand or otherwise modify UNSEMI's terms and conditions of purchase, including but not limited to the warranty expressed therein.

Unless otherwise agreed in writing, UNSEMI product is not designed, authorized or warranted to be suitable for use in medical life-saving, or life-sustaining application , nor in applications where failure or malfunction of a UNSEMI product can reasonably be expected to result in personal injury, death or severe property or environmental damage. UNSEMI and its suppliers accept no liability for inclusion or use of UNSEMI products in such equipment or applications and therefore such inclusion and/or use is at the customer's own risk.

All referenced brands, product names, service names and trademarks are the property of their respective owners.